



EPT20-15ET2H

All-terrain Electric Pedestrian Pallet truck 1.5T



- Mature components ensuring reliability
- Waterproof and dust-proof design for rough environments
- Optimized drive wheel to cope with heavy duties and continuous use
- Higher ground clearance available for outdoor usage

Manufacturer			EP
Model designation			EPT20-15ET2H
Drive			Electric
Load capacity	Q	kg	1500
Load center distance	c	mm	600
Service weight			kg
Length to face of forks	l2	mm	554
Overall width	b1/b2	mm	685
Fork dimensions	s/e/l	mm	50/150/1150
Turning radius	Wa	mm	1505
Max. gradeability, laden/unladen			%
Battery voltage/nominal capacity			V/Ah
			24V/65



FEATURE

■ Mature components ensuring reliability

The EPT20-15ET2H inherits the design philosophy of EP's iconic model, EPT20-15ET2, along with market-proven components, AGM battery and standard integrated charger, which convince users of its good quality and reliability.



■ Waterproof and dust-proof design for rough environments

The EPT20-15ET2H adopts the fully closed connectors and gearbox, protecting the truck from water or dust ingress. This makes it a workhorse even in muddy and wet scenarios.

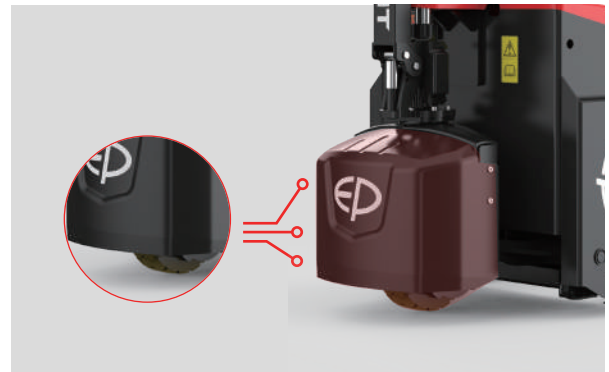

■ Optimized drive wheel to cope with heavy duties and continuous use

To cope with heavy duties, EP optimizes the drive wheel and it's easy to swap in case of wear sustained from continuous use. Operators benefit from the truck in terms of durability and easy maintenance.



■ Higher ground clearance available for outdoor usage

The EPT20-15ET2H features high ground clearance to accommodate transportation tasks on uneven surfaces and rough environments like construction sites.



Electric Pedestrian Pallet truck 1.5T

EPT20-15ET2H

Distinguishing mark	1.1	Manufacturer			EP
	1.2	Model designation			EPT20-15ET2H
	1.3	Drive			Electric
	1.4	Operator type			Pedestrian
	1.5	Load capacity	Q	kg	1500
	1.6	Load center distance	c	mm	600
	1.8	Load distance, centre of drive axle to fork	x	mm	946
	1.9	Wheelbase	y	mm	1301
	Service weight	2.1	Service weight		kg
2.2		Axle loading, laden front/rear		kg	724/1468
2.3		Axle loading, unladen front/rear		kg	165/40
Tyres/chassis	3.1	Tyre type			Rubber/PU
	3.2	Tyre size, front			Φ210x70
	3.3	Tyre size, rear			Φ80x61 /105X88
	3.4	Additional wheels (castor wheels)		mm	—
	3.5	Wheels, number front/rear (x=drive wheels)		mm	1x, — /4
	3.6.1	Tread width, front	b ₁₀	mm	—
	3.7.1	Tread width, rear	b ₁₁	mm	410 (535)
Dimensions	4.4	Lift height	h ₈	mm	115
	4.9	Height of tiller handle in drive position min./max.	h ₁₄	mm	790/1250
	4.15	Lowered height	h ₁₃	mm	80
	4.19	Overall length	l ₁	mm	1704
	4.20	Length to face of forks	l ₂	mm	554
	4.21	Overall width	b ₁ /b ₂	mm	685
	4.22	Fork dimensions	s×e×l	mm	50/150/1150
	4.25	Distance between fork-arms	b ₅	mm	560 (685)
	4.32	Ground clearance, center of wheelbase	m ₂	mm	30
	4.34.1	Aisle width for pallets 1000×1200 crossways	Ast	mm	2307
	4.34.2	Aisle width for pallets 800×1200 lengthways	Ast	mm	2179
4.35	Turning radius	Wa	mm	1505	
Performance data	5.1	Travel speed, laden/unladen		km/h	4/4 .5
	5.2	Lifting speed, laden/unladen		m/s	0.027/0.038
	5.3	Lowering speed, laden/unladen		m/s	0.059/0.039
	5.8	Max. gradeability, laden/unladen		%	5/16
	5.10	Service brake			Electromagnetic
Electric-engine	6.1	Drive motor rating S2 60 min		kW	0.75
	6.2	Lift motor rating at S3 15%		kW	0.8
	6.4	Battery voltage/nominal capacity		V/Ah	24V/65
	6.5	Battery weight		kg	34
Addition data	8.1	Type of drive control			DC
	10.5	Steering design			Mechanical
	10.7	Sound pressure level at the driver's ear		dB(A)	74

If there are improvements of technical parameters or configurations, no further notice will be given.
The diagram shown may contain non-standard configurations.

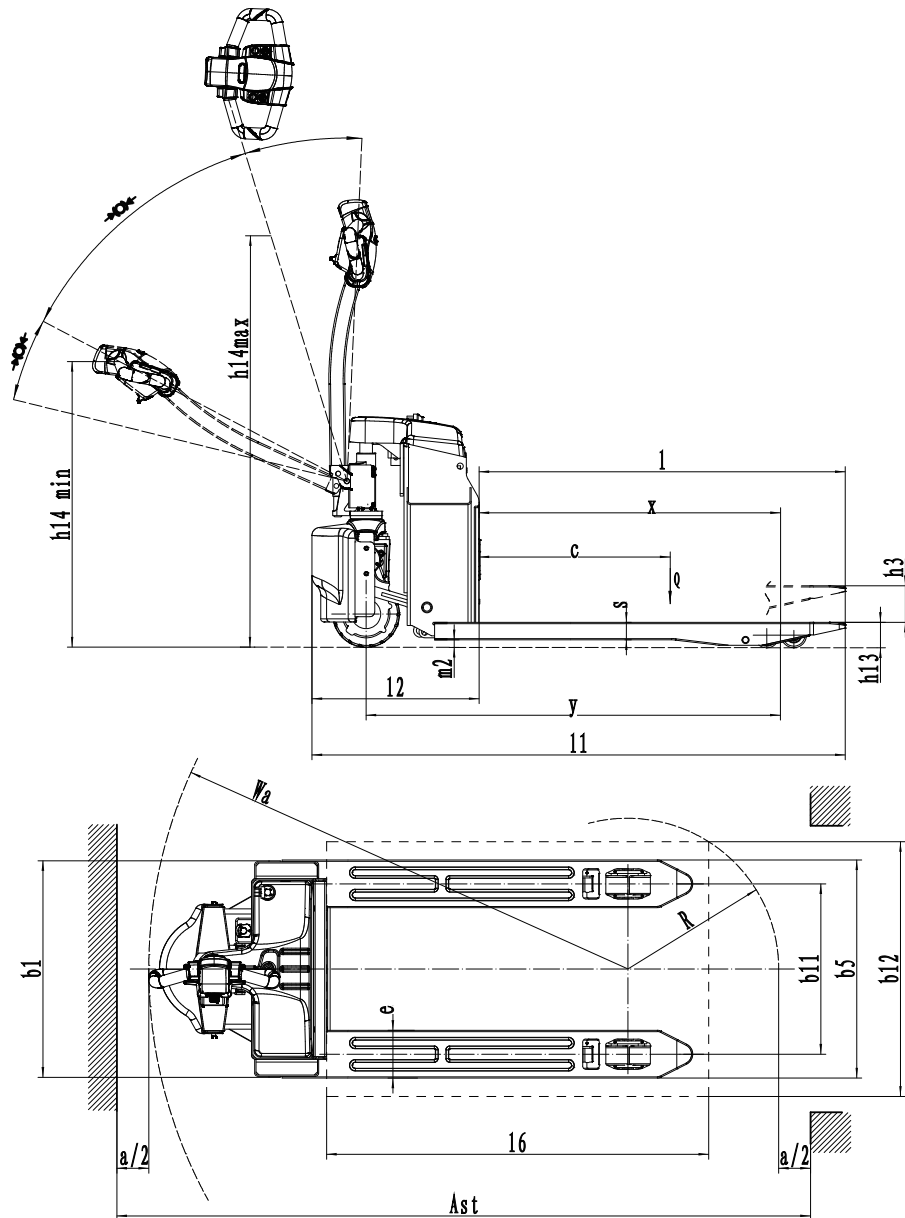

Option:

No.	Optional items	EPT20-15ET2H
1.1	Fork dimension	<ul style="list-style-type: none"> ●560*1150 ○560*800、1000、1220、1300、1400、1500、1600、1800、2000 ○685*800、1000、1150、1220、1300、1400、1500、*1600、1800、2000
1.3	Fork lowered height	● 80
1.5	Backrest height	●No○1220mm (48in) ○1520mm (60in)
1.6	Drive cover off the ground	●70mm
2.1	Load wheel type	●Double○Single
2.2	Load wheel material	●PU
2.3	Drive wheel material	●Rubber○PU
2.7	Battery capacity	●65Ah AGM○85Ah AGM
2.8	Charger	●24V-10A
2.9	Battery indicator	●With hourtime
3.3	Castor wheels	●No○Yes and not customized
3.16	Turtle speed	●Yes and not customized

Note: ●Standard ○ Optional - Inconformity